

Quick-Absorb Steam Humidifier

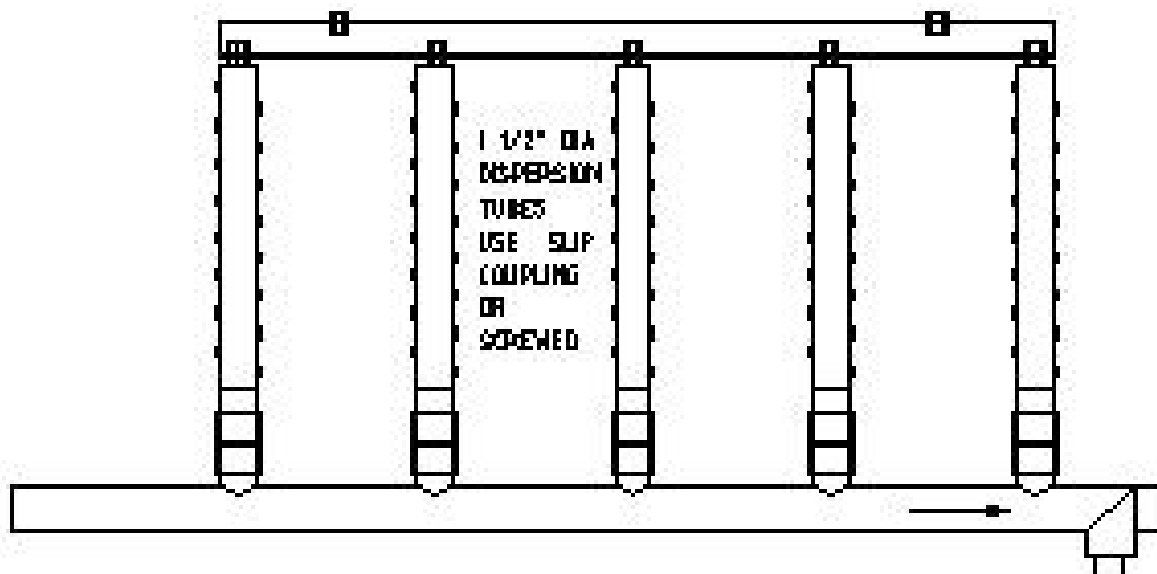

GENERAL DESCRIPTION

The BEST A/V QUICK-ABSORB steam humidifier is designed to achieve a rapid, thorough, and drip-free humidification. It is an economic and ideal steam dispersion tube panel for limited absorption distance and middle capacity system. Also allowing installed within few inches away from devices in upstream and about 2-4 feet from devices in downstream. And with stainless steel construction and most fittings ensure a long-life span and a minimal or no maintenance.

KEY FEATURES

Low Cost:

- I Economical type dispersion tube panel.

Material:

- I All tubes are made of stainless steel 304 and joints welded with same quality fusion
- I Last for a long-life span
- I High resistance to corrosive steam, such as RO/DI pure water
- I Attractive outlook

Super-Short Absorption Distance:

- I Can be installed within inches away from downstream devices without condensation on the devices such as fans, heating/cooling coils, and damper....
- I If it is necessary to install Quick-Absorb upstream

of HEPA (high efficiency filters), consult with the factory for recommendations.

Super-Low Steam Pressure:

- I Only few ounces of pressure are needed for moving the steam through the dispersion panel and no need of steam jacketing.

No-Drip Humidifying:

- I The unique design of steam dispersion tubes, nozzles and header that separate the steam from water. No need of steam - jacketing to prevent condensation spitting.

Non-Metallic Nozzles:

The nozzles are made of Polyphenylene sulfide, which

- I Stands high temperature up to 270°C and complies with UL standard of 220°C~240°C continued operation.
 - I Fireproof complies with ul97v-0.
 - I Chemical-proof when operated below 220°C.
- Nozzles are plugged into the middle of the hose as to dispersing the most quality steam to the space.

Only Dry Steam Dispersed:

- I By means of centering the non-metallic nozzles in the tubes, there the most active dry steam will be carried out of the tubes and dispersed into space.

Super-Low Resistance To Air Flow:

- I Spacing between tubes is designed closely so that it is relatively low in resistance with the air flow and hence would not degrade the absorption

performance at all.

Rapid Humidifying:

- I Advantages of short absorption, low steam pressure, no drip, dry steam output, and low air resistance, ensuring a quick and thorough humidification.

Lowong Costs On Installation Related Expenses:

- I With the shorter length of air handler needed, obviously the construction and installation time and expenses for air handler would be then much lower.

Easy And Quick Installation:

- I Since the face dimension of dispersion panel (not including header) is equivalent to heating/cooling bank dimension, so the Quick-Absorb can be pre-assembled in factory and shipped as a package unit. When installing, simply mounting the unit in place of air handlers or ducts and completing condensation and steam connections.

Two-Year Limited Warranty:

Best A/V Quick-Absorb humidifier warrants to the original user that its products will be free from defects in materials and workmanship for a period of two years after delivery.

Wide Range Of Capacity:

- I Customized
- I Max. 176 kg/hr-m²

Piping And Connections (Optional):

- I Steam hose
- I Screwed
- I Slip-on flanged PN16, JIS10K, or ANSI 150#

Spare Parts (Optional):

- I Nozzle
- I Rings (set of 4)
- I Slip coupling - non-metallic, stainless steel, or brass

V-Tube Dispersion Panel (Optional):

This V-Tube Dispersion Panel featured a V shape guiding plate, which

- I Guides the steam into the desired direction or into the room/space where humidification is needed.
- I Reduces heat-loss

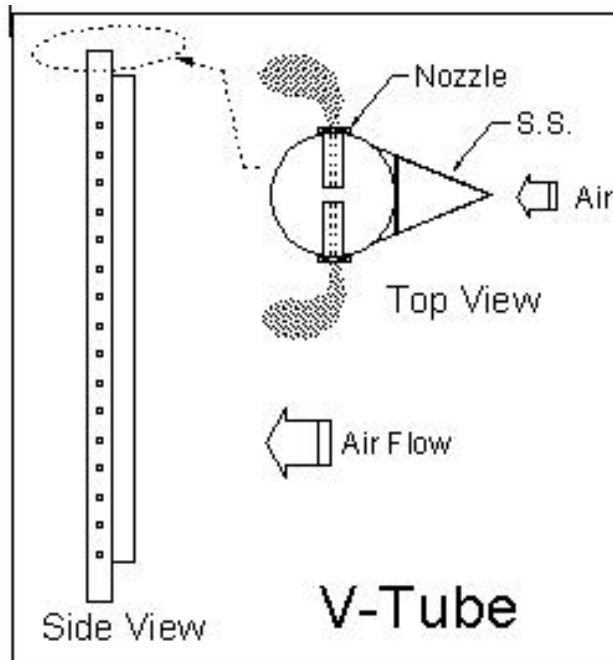

D-Tube Dispersion Panel (Optional):

- I D-Tube Dispersion Panel is with a coating of 3mm thick EPDM which can stand high temperature. D-Tube's features
- I Effectively reducing heat-loss
- I Increasing steam utilization

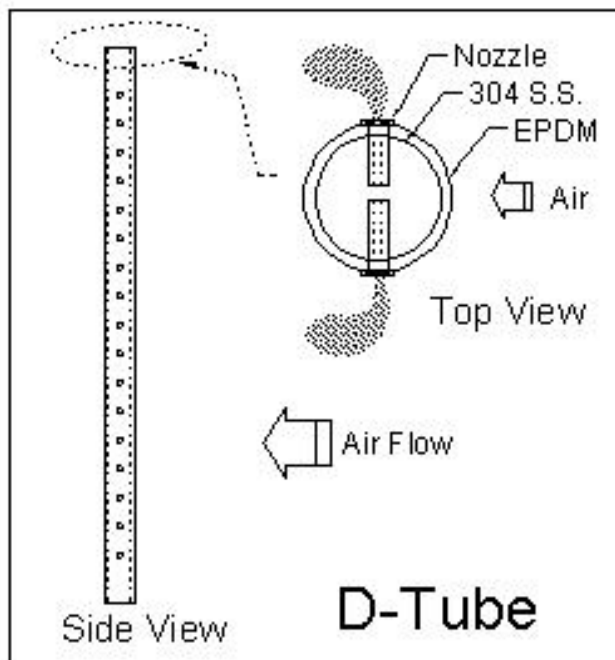

COMPONENTS AND MATERIALS:

No	PART	MATERIAL
1	Tube	Stainless Steel 304
2	Nozzle	Non-metallic
3	Header	Stainless Steel 304
4	Mounting Channel	Stainless Steel 304
5	Slip Coupling	Non-metallic
6	O-Ring	FKM
7	Steam Inlet	Stainless Steel 304
	Slip-on Flanged	Carbon Steel
	Option - Slip-on Flanged	Stainless Steel 304

Note: 316 Stainless Steel Alloy or other material can be specified. Slip-on flanged up to 3" pipe is standard.

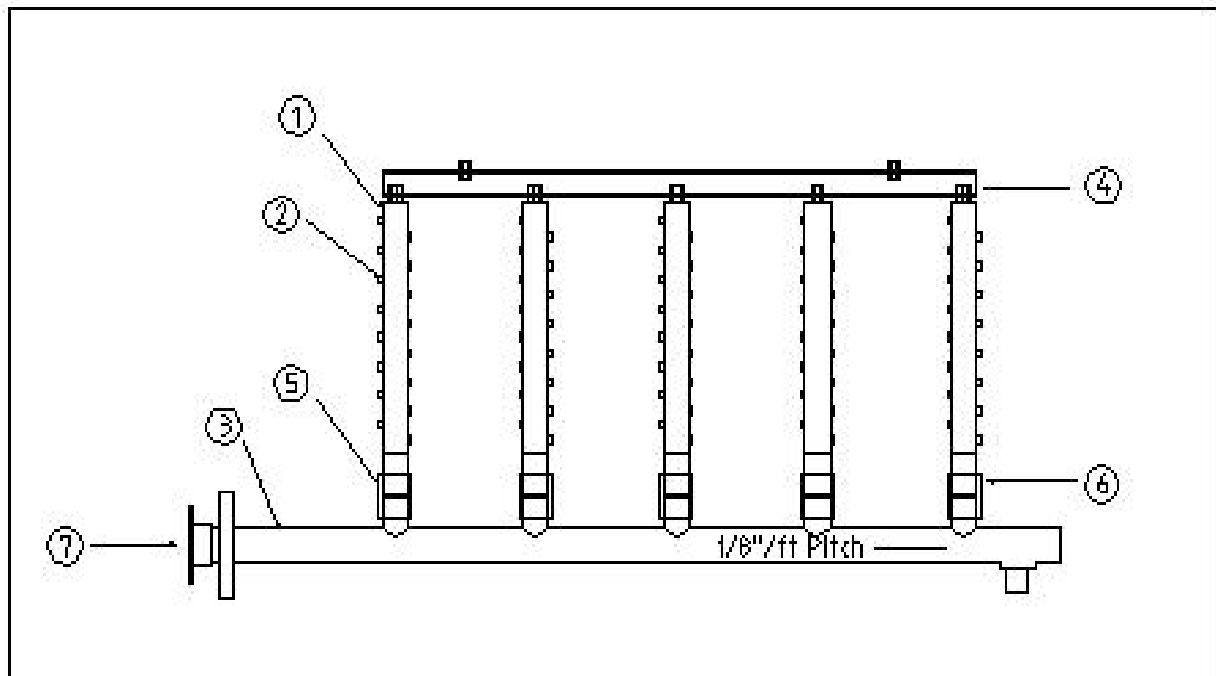



HOW TO ORDER

Below is an example given to help you in selecting the right type and capacity for Quick-Absorb and meeting your specific need.

Conditions:

- I 100% make-up air unit
- I Heating/cooling coil bank: 2 sq m (wide) x 2 sq m (high) = 4 sq m
- I Non-wetting distance (between air blower and Quick-Absorb unit): 1 M
- I Air volume: 10 CMS
- I Entering air condition (entering RH): 5°C / 50%RH
- I Desired air condition (leaving RH): 14°C / 90%RH

Calculating the required humidification load:

- I Check on Table Quick-1 and get following figures
- I Entering RH = 5°C / 50%RH
= 0.342 kg/s per 100 m³/s A
- I Leaving RH = 14°C / 90%RH
= 1.091 kg/s per 100 m³/s B
- I Then the rising moisture = B - A
= 1.091 - 0.342 = 0.749 kg/sC
- I Humidification load
= Air volume x C ÷ 100m³/s x 3600 s/hr
= 10 m³/s x 0.749 ÷ 100 x 3600
= 270 kg/hr

How to determining the Rise RH:

The rise RH is the condition of air entering into Quick-Absorb. Check on Table Quick-1 and then

- I Locate entering temperature 5°C and read horizontally to the right at 50%RH to get moisture figure 0.342 for entering air
- I Locate leaving temperature 14°C and read horizontally to the right to get an equivalent moisture figure 0.364 to above 0.342 (entering air moisture).
- I Revealed from the Table Quick-1, the %RH for 0.364 is 30%RH. So, the Rise RH is 30%.

Determining Tube Spacing for Quick-Absorb:

Following steps show you how to get the tube spacing:

- I Take the capacity needed and divided by coil face area. Which is
 $270 \text{ kg/hr} / 4 \text{ sq m} = 67.5 \text{ kg/hr-m}^2$
- I Tube spacing available: Check on Table Quick-3 to see which's Max. Capacity is larger than 67.5

kg/hr- m². We get tube spacing 150mm, 110mm, and 75mm. Note that the larger the tube spacing the less the cost would be.

- I Non-wetting Distance VS Tube spacing: Check on Table Quick-2, start with the entering RH 50% and go straight up till reaching the leaving RH 90% line from left. Then go horizontally to the right till reaching the "A" line from the left. Go straight up again till you find the first one of 100cms (1M) non-wetting distance. And from 100cms go horizontally left and get tube spacing as 150mm.
- I From available tube spacing and limitation of non-wetting distance. We can see the 150mm is the most suitable one.

Double-checking:

In order to make sure that selected 150mm tube spacing is providing sufficient capacity as needed. You need to make a recheck as followings:

- I The dispersion panel face dimension (not including header) shall approximately close to the upstream heating/cooling coil bank dimension, so the dispersion panel face area is about 4 sq m.
- I Check on the Table Quick-3 and get a max. of 88 kg/hr-m² for tube spacing of 150mm. That would produce (4 sq m x 88 kg/hr-m² =) 352 kg/hr humidification loads, which would provide adequate capacity, as needed of 270 kg/hr loads.
- I If above outcome figure is inadequate, then select the 110 mm tube spacing to suit the specific humidification load needed.

Determining Head Size for Quick-Absorb:

Take the capacity 270 kg/hr and check with Table Quick-4 to get the capacity is about 10% larger than 270 kg/hr to cover up the possible heat loss. So,

- I If your energy source is Boiler, then the 3" header size is the right one. The 2" is a bit smaller than needed.
- I If you use steam generator, then 4" header size is the most suitable one.



Table Quick-1 Humidification Loads Calculating Chart Kg/Hr-CMS

Dry Bulb Air Temp. (°C)	10%	20%	30%	35%	40%	45%	50%	55%	60%	65%	70%	75%	80%	85%	90%	100%
-10	0.022	0.043	0.065	0.075	0.086	0.097	0.108	0.118	0.129	0.140	0.151	0.161	0.172	0.183	0.194	0.215
-9	0.023	0.047	0.070	0.082	0.094	0.105	0.117	0.129	0.140	0.152	0.164	0.176	0.187	0.199	0.211	0.234
-8	0.026	0.051	0.077	0.089	0.102	0.115	0.128	0.140	0.153	0.166	0.179	0.191	0.204	0.217	0.230	0.255
-7	0.028	0.055	0.083	0.097	0.111	0.125	0.139	0.152	0.166	0.180	0.194	0.208	0.222	0.235	0.249	0.277
-6	0.030	0.060	0.090	0.105	0.120	0.135	0.151	0.166	0.181	0.196	0.211	0.226	0.241	0.256	0.271	0.301
-5	0.033	0.065	0.098	0.114	0.130	0.147	0.163	0.179	0.196	0.212	0.228	0.245	0.261	0.277	0.293	0.326
-4	0.035	0.071	0.106	0.124	0.142	0.159	0.177	0.195	0.212	0.230	0.248	0.266	0.283	0.301	0.319	0.354
-3	0.038	0.077	0.115	0.134	0.153	0.172	0.192	0.211	0.230	0.249	0.268	0.287	0.306	0.326	0.345	0.383
-2	0.042	0.083	0.125	0.145	0.166	0.187	0.208	0.228	0.249	0.270	0.291	0.311	0.332	0.353	0.374	0.415
-1	0.045	0.090	0.135	0.158	0.180	0.203	0.225	0.248	0.270	0.293	0.315	0.338	0.360	0.383	0.405	0.450
0	0.049	0.097	0.146	0.170	0.195	0.219	0.244	0.268	0.292	0.317	0.341	0.365	0.390	0.414	0.438	0.487
1	0.052	0.105	0.157	0.183	0.210	0.236	0.262	0.288	0.314	0.341	0.367	0.393	0.419	0.445	0.472	0.524
2	0.056	0.113	0.169	0.197	0.225	0.253	0.282	0.310	0.338	0.366	0.394	0.422	0.450	0.479	0.507	0.563
3	0.061	0.121	0.182	0.212	0.242	0.272	0.303	0.333	0.363	0.393	0.424	0.454	0.484	0.514	0.545	0.605
4	0.065	0.130	0.195	0.228	0.260	0.293	0.325	0.358	0.390	0.423	0.455	0.488	0.520	0.553	0.585	0.650
5	0.068	0.137	0.205	0.239	0.273	0.307	0.342	0.376	0.410	0.444	0.478	0.512	0.546	0.581	0.615	0.683
6	0.073	0.147	0.220	0.257	0.293	0.330	0.367	0.403	0.440	0.476	0.513	0.550	0.586	0.623	0.660	0.733
7	0.079	0.157	0.236	0.275	0.314	0.354	0.393	0.432	0.472	0.511	0.550	0.590	0.629	0.668	0.707	0.786
8	0.084	0.168	0.253	0.295	0.337	0.379	0.421	0.463	0.505	0.547	0.589	0.632	0.674	0.716	0.758	0.842
9	0.090	0.180	0.271	0.316	0.361	0.406	0.451	0.496	0.541	0.586	0.631	0.677	0.722	0.767	0.812	0.902
10	0.094	0.189	0.283	0.330	0.378	0.425	0.472	0.519	0.566	0.614	0.661	0.708	0.755	0.802	0.850	0.944
11	0.101	0.201	0.302	0.352	0.402	0.452	0.503	0.553	0.603	0.653	0.704	0.754	0.804	0.854	0.905	1.005
12	0.107	0.214	0.321	0.375	0.428	0.482	0.535	0.589	0.642	0.696	0.749	0.803	0.856	0.910	0.963	1.070
13	0.114	0.228	0.342	0.399	0.456	0.513	0.570	0.626	0.683	0.740	0.797	0.854	0.911	0.968	1.025	1.139
14	0.121	0.242	0.364	0.424	0.485	0.545	0.606	0.667	0.727	0.788	0.848	0.909	0.970	1.030	1.091	1.212
15	0.129	0.258	0.387	0.451	0.516	0.580	0.645	0.709	0.773	0.838	0.902	0.967	1.031	1.096	1.160	1.289
16	0.137	0.275	0.412	0.481	0.549	0.618	0.687	0.755	0.824	0.892	0.961	1.030	1.098	1.167	1.236	1.373
17	0.145	0.291	0.436	0.509	0.581	0.654	0.727	0.799	0.872	0.944	1.017	1.090	1.162	1.235	1.308	1.453
18	0.154	0.308	0.463	0.540	0.617	0.694	0.771	0.848	0.925	1.002	1.079	1.157	1.234	1.311	1.388	1.542
19	0.164	0.328	0.492	0.574	0.656	0.738	0.820	0.901	0.983	1.065	1.147	1.229	1.311	1.393	1.475	1.639
20	0.174	0.347	0.521	0.608	0.694	0.781	0.868	0.955	1.042	1.128	1.215	1.302	1.389	1.476	1.562	1.736
21	0.184	0.368	0.552	0.644	0.736	0.828	0.920	1.012	1.104	1.196	1.288	1.380	1.472	1.564	1.656	1.840
22	0.195	0.390	0.585	0.683	0.780	0.878	0.975	1.073	1.170	1.268	1.365	1.463	1.560	1.658	1.755	1.950
23	0.206	0.412	0.617	0.720	0.823	0.926	1.029	1.132	1.235	1.338	1.441	1.544	1.646	1.749	1.852	2.058
24	0.219	0.437	0.656	0.765	0.874	0.984	1.093	1.202	1.312	1.421	1.530	1.640	1.749	1.858	1.967	2.186
25	0.231	0.463	0.694	0.810	0.925	1.041	1.157	1.272	1.388	1.503	1.619	1.735	1.850	1.966	2.082	2.313
26	0.245	0.489	0.734	0.856	0.978	1.101	1.223	1.345	1.468	1.590	1.712	1.835	1.957	2.079	2.201	2.446
27	0.259	0.517	0.776	0.905	1.034	1.164	1.293	1.422	1.552	1.681	1.810	1.940	2.069	2.198	2.327	2.586
28	0.273	0.547	0.820	0.957	1.093	1.230	1.367	1.503	1.640	1.776	1.913	2.050	2.186	2.323	2.460	2.733
29	0.289	0.577	0.866	1.010	1.155	1.299	1.444	1.588	1.732	1.877	2.021	2.165	2.310	2.454	2.598	2.887
30	0.305	0.610	0.914	1.067	1.219	1.372	1.524	1.676	1.829	1.981	2.134	2.286	2.438	2.591	2.743	3.048
31	0.322	0.644	0.965	1.126	1.287	1.448	1.609	1.770	1.931	2.092	2.253	2.414	2.574	2.735	2.896	3.218
32	0.339	0.679	1.018	1.188	1.358	1.527	1.697	1.867	2.036	2.206	2.376	2.546	2.715	2.885	3.055	3.394



Table Quick-2 Absorption Distances (cm)

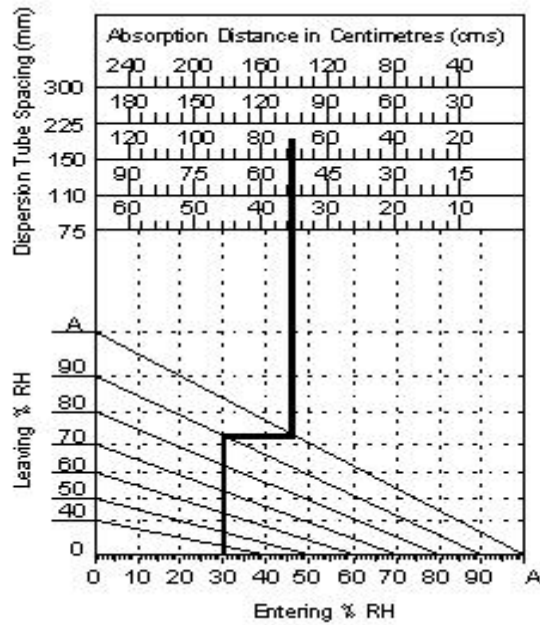

Table Quick-3 Steam Flow Sizing/Capacities

Tube Spacing (mm)	75	110	150	225
Max. Capacity (kg/hr-m ²)	176	132	88	58

Table Quick-4 Header Sizing/Capacities (kg/hr)

Header Size	Steam Boiler	Low Pressure Steam Generator
2"	270	110
3"	450	220
4"	800	360
5"	1250	590
6"	1800	950

Table Quick-5 Pressure Loss (mm/cm²)

Duct Air Velocity (M/S)	Tube Spacing		
	75mm	110mm	150mm
2.5	0.5	0.39	0.25
5	2.0	1.48	0.635
7.5	4.3	3.17	1.27

Note: 225mm tube spacing have no measurable air pressure loss.



OPERATION

Followings are principles of operation:

- I Steam from evaporating chamber via steam hose or hard tube entering the supply header
- I Steam travel through supply header and channel through each tubes within the dispersion panel
- I The driest steam passes through the centered and closely arrayed nozzles in the tubes and then dispersed into space.
- I Condensation would cling to inner wall of each tubes and then drain out via condensation header to the floor drain.

INSTALLATION

Following are principles of installation:

- I Only qualified personnel should perform all installation procedures.
- I Leaving enough space for safety installing, repairing, maintaining, and draining operation.
- I Ideal location: near downstream of heating/cooling coil bank to ensuring an even and 100% make-up air flow supply
- I The dispersion panel face area (not including header) shall be equivalent to the heating/cooling coil bank or duct dimension, allowing enough space for condensation piping.
- I Highly recommend to locating the unit near humidifier for a rapid, thorough absorption of steam and best humidification.
- I Locate the unit at the most active part of the air stream to providing rapid, thorough absorption of the steam; and keeping away from dead spots such as the elbow and baffle plate area.
- I Locate the unit near where the vapor being discharged will be carried off along with the air stream and will not result condensation or dripping from the duct.
- I Avoid locating the unit near a split in the duct, preventing uneven moisture between branch ducts.
- I Avoid places like the water vapor will impinge on a metal surface or high efficiency filter.
- I In the event of saturation may occur (revealed from the Psychrometric Chart), should equip with a high limit humidistat or a thermostat and set to cut off the humidifier at a safe temperature

INSTALLING in the duct:

**BEST A/V QUICK-ABSORB STEAM HUMIDIFIER
HEADER BELOW THE DUCT**

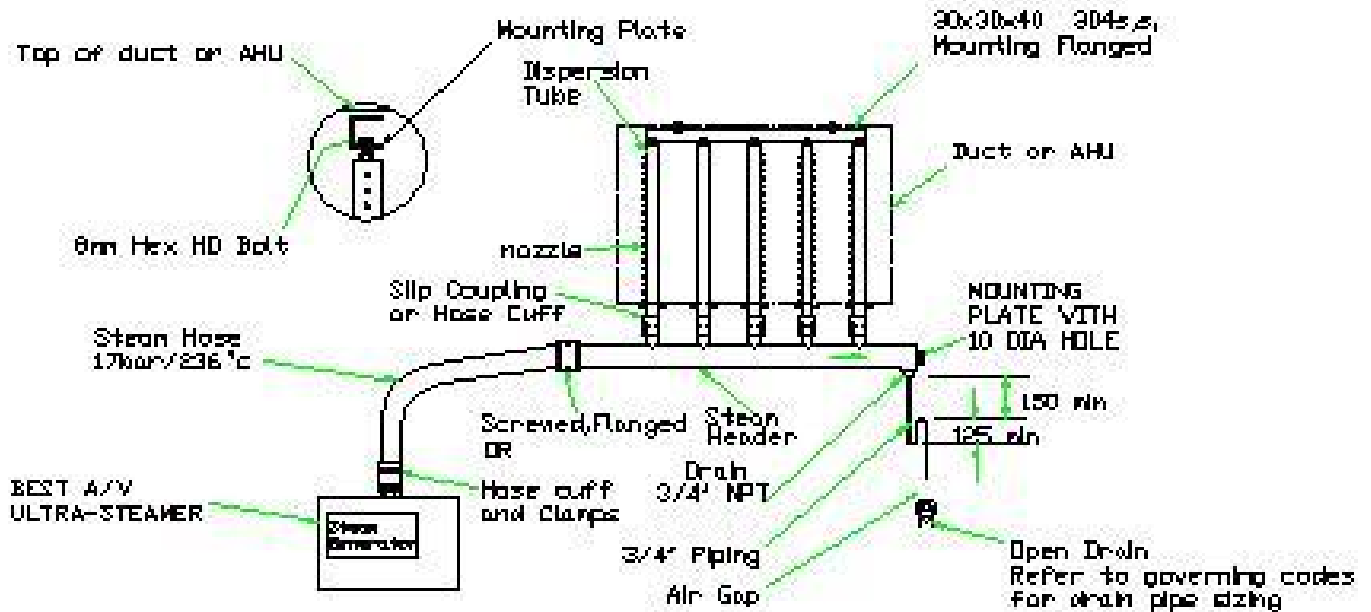

INSTALLING Quick-Absorb with steam trap in AHU:



TAG NO. _____

AHU Size : Width : _____ mm
 Height : _____ mm
 Req. Capacity : _____ Kg/Hr
 Tube Spacing : _____ mm
 Dispersion Tube : _____ PCS
 Connection Type : _____
 Connection Size : _____ mm
 Connection Q'TY : _____ PCS
 Absorption Distances : _____ mm
 Capacity : _____ Kg/Hr-M2
 Steam Pressure : _____ Mbar
 Nozzle : _____ Pcs

Tube for Quick-Absorb

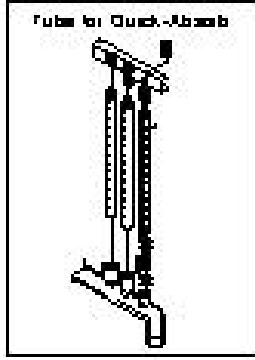

Quick-Absorb for Steam Trap in AHU

REVISION DATE: 01/04/00	REVISED DATE: 05/25/00	VERSION	LAYOUT DATE
-------------------------	------------------------	---------	-------------

翰華股份有限公司
 TAIPEI-307888 TEL: (3-2657)6522

INSTALLING Quick-Absorb with water seal in AHU:

